



# General machining

Specialty lubricants for  
metalworking and metal forming

---



**BECHEM**  
LUBRICATION  
TECHNOLOGY

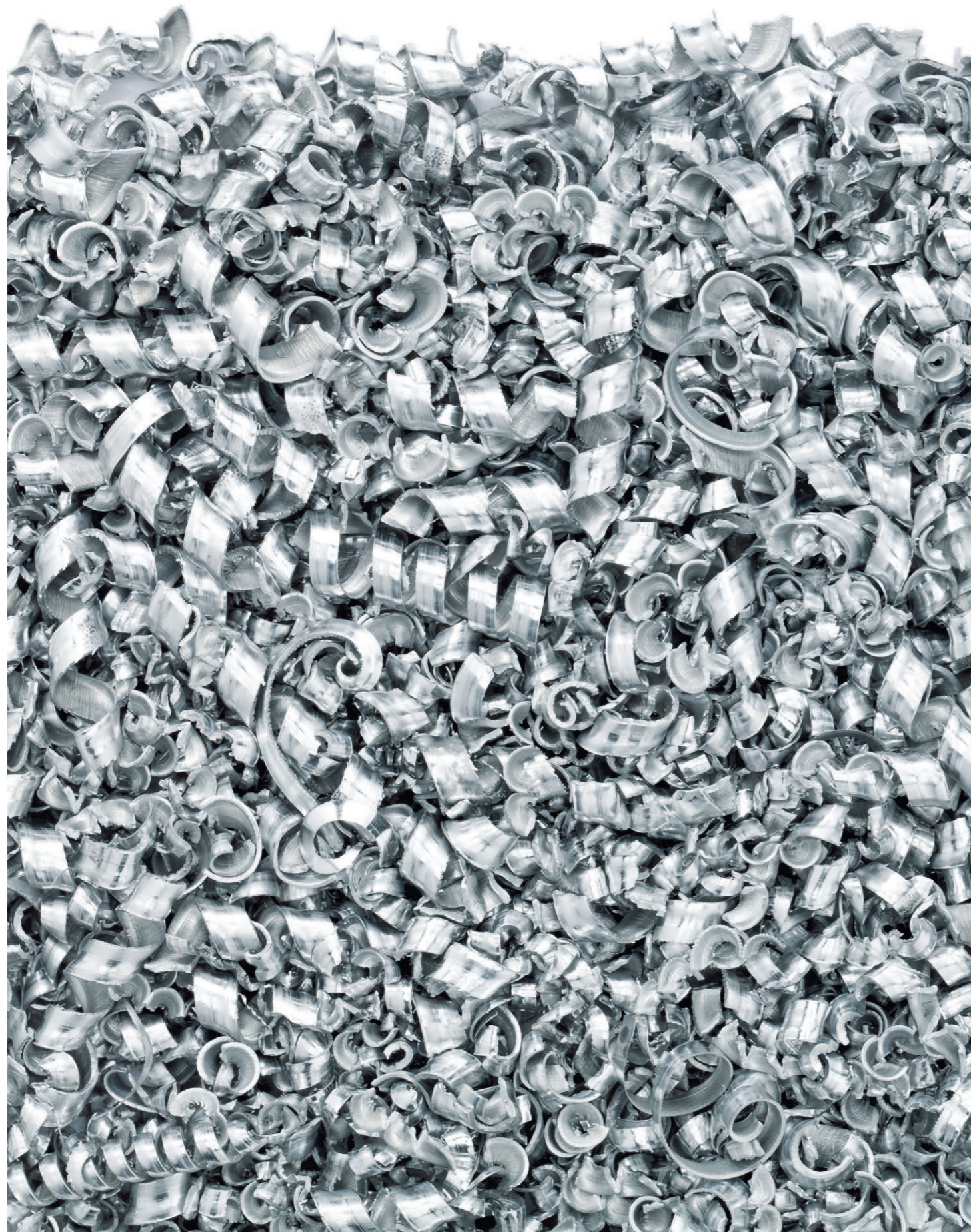

# Lubrication solutions for general machining

BECHEM – Lubrication solutions for industry

















As the oldest German manufacturer of industrial lubricants, BECHEM is one of the leading producers of high-quality special lubricants and metalworking fluids today.

BECHEM products stand out through innovative formulations in the most diverse industrial applications – in machining and forming for metalworking processes, in coating technology and as for-life lubricants in various technical components.













A strong network of distributors and several national and international production sites ensure that BECHEM products are readily available worldwide.

**Lubricants reimagined. Since 1834.**

## APPLICATIONS

- Tool manufacture 
- Deep drilling 
- Broaching 
- Grinding 
- Turning 
- Drilling 
- Milling 
- Honing 
- Sawing 
- Deep drawing 
- Punching 
- Bending 
- Roller bearings 
- Plain bearings 
- Open gears 
- Closed gears 
- Chains 

## PROPERTIES

- Corrosion protection 
- Chlorine free 
- Low residue level 
- Good rinsing performance 
- Low foaming 
- Extended tool life 
- High loads 
- Resistant to water 
- High speed 
- Noise dampening 
- Low temperatures 
- High temperatures 

All indications and values correspond to latest knowledge and do not represent any product specification

# Lubrication solutions for the entire process chain

Everything from one source: BECHEM lubricants ensure maximum efficiency and performance over the entire process chain. For all process steps, from general machining, cleaning and corrosion protection, BECHEM developed a fine-tuned product series offering a wide range of benefits.

Due to extended lifetime; maintenance is reduced, productivity is increased and the process is continuously improved. In addition, fewer suppliers enables lower cost and more efficient use of the lubricant. Cost-intensive damage and machine downtime can be prevented.

Ideal process maintenance is crucial for the extended lifetime and functionality of wire producing assets. BECHEM provides technical consultation on the proper use of various lubricants, offering added value in terms of safety and reliability in production.

With its BECHEM Avantin, Berucut, Beruclean and Beruprotect product lines, BECHEM offers a highly capable range of products for machining that exceed growing customer requirements in terms of environmental regulations, optimizing processes and combining methods. BECHEM products achieve a high cooling effect, excellent performance and enable efficiency improvements.

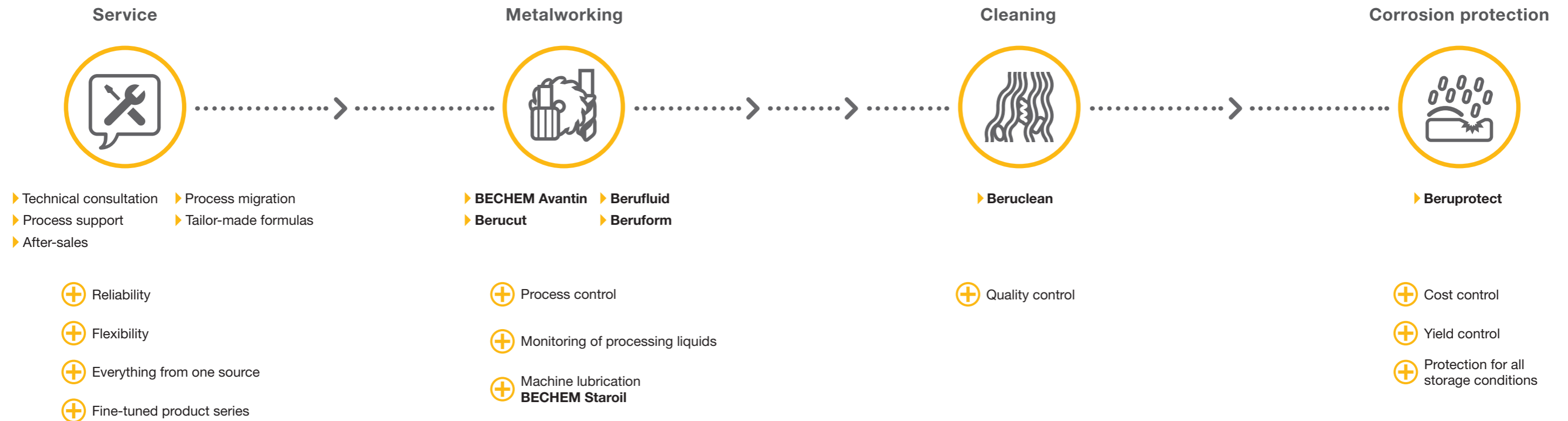

# Process media for metal removal and forming technology

## FRONT AXLE ASSEMBLY

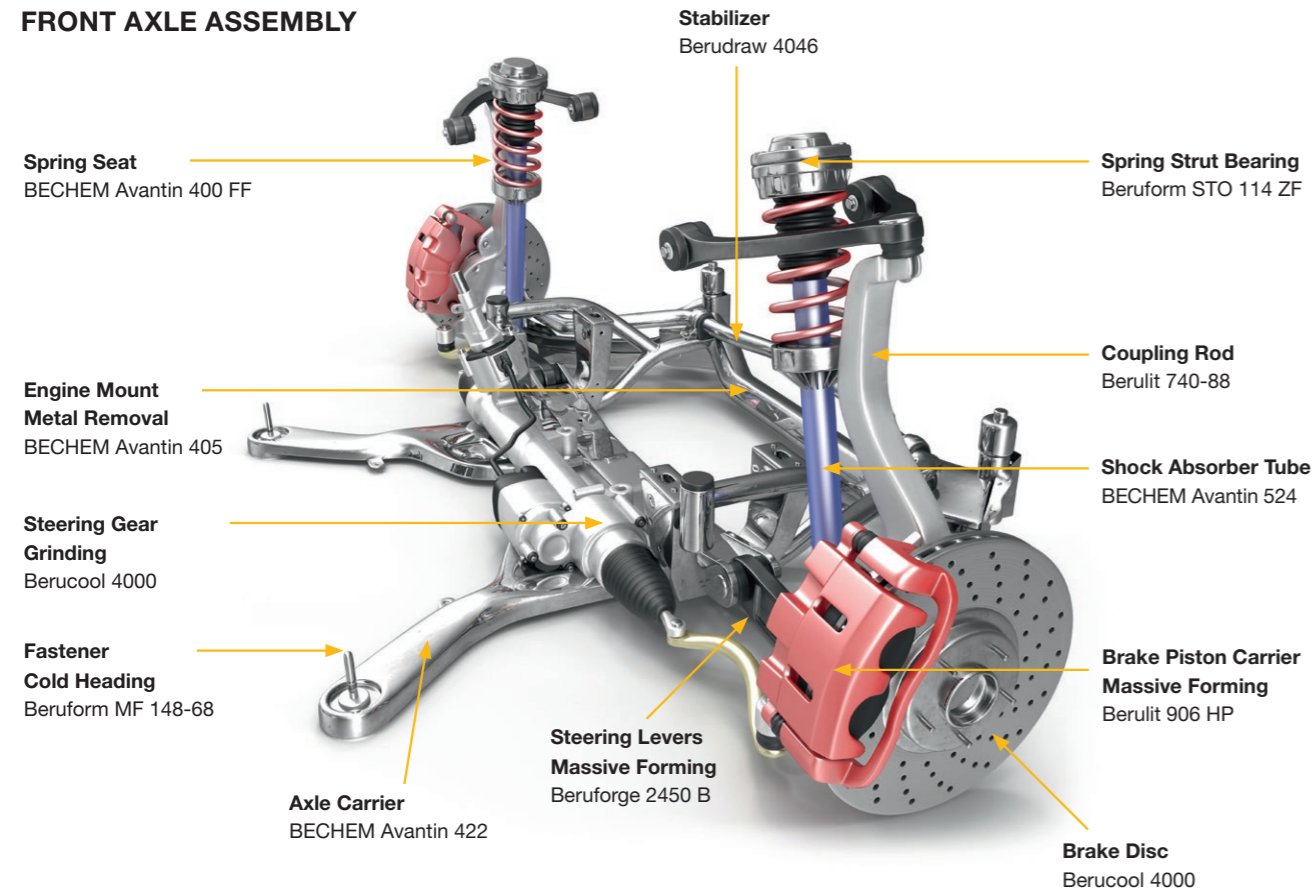

## AUTOMATIC TRANSMISSION ASSEMBLY

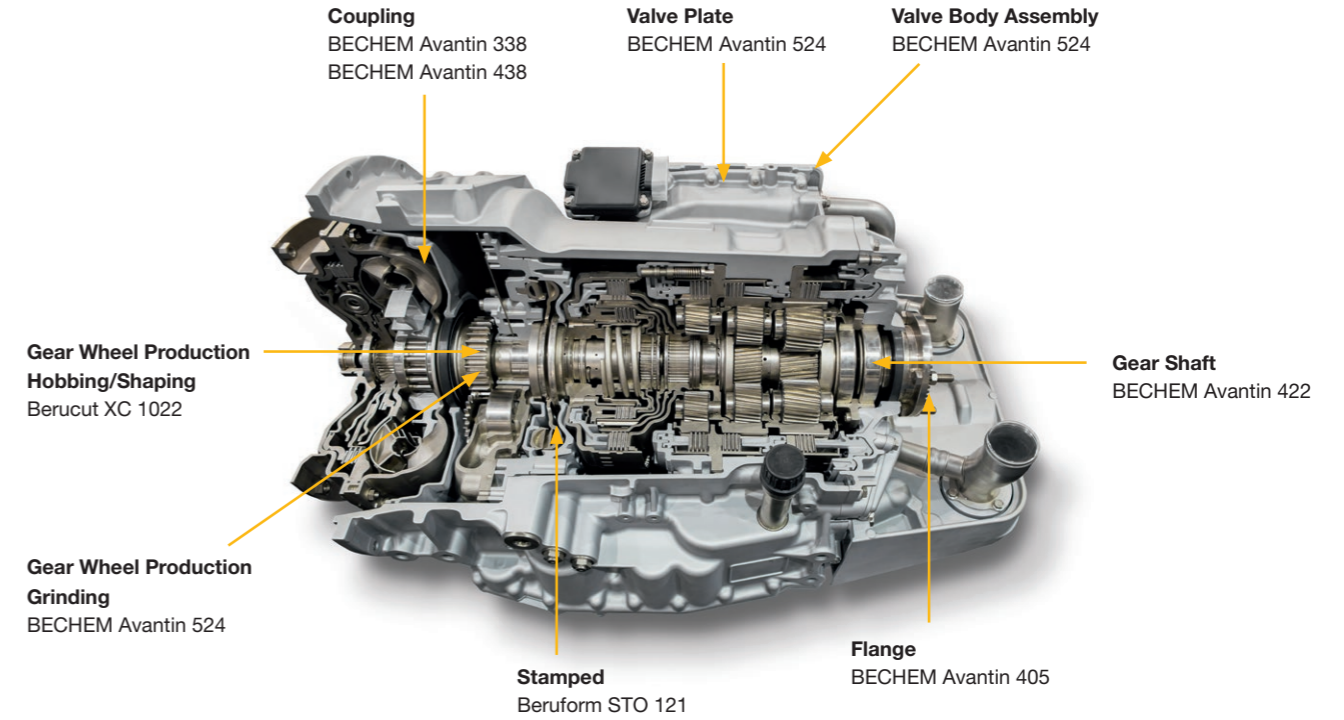

## REAR AXLE ASSEMBLY

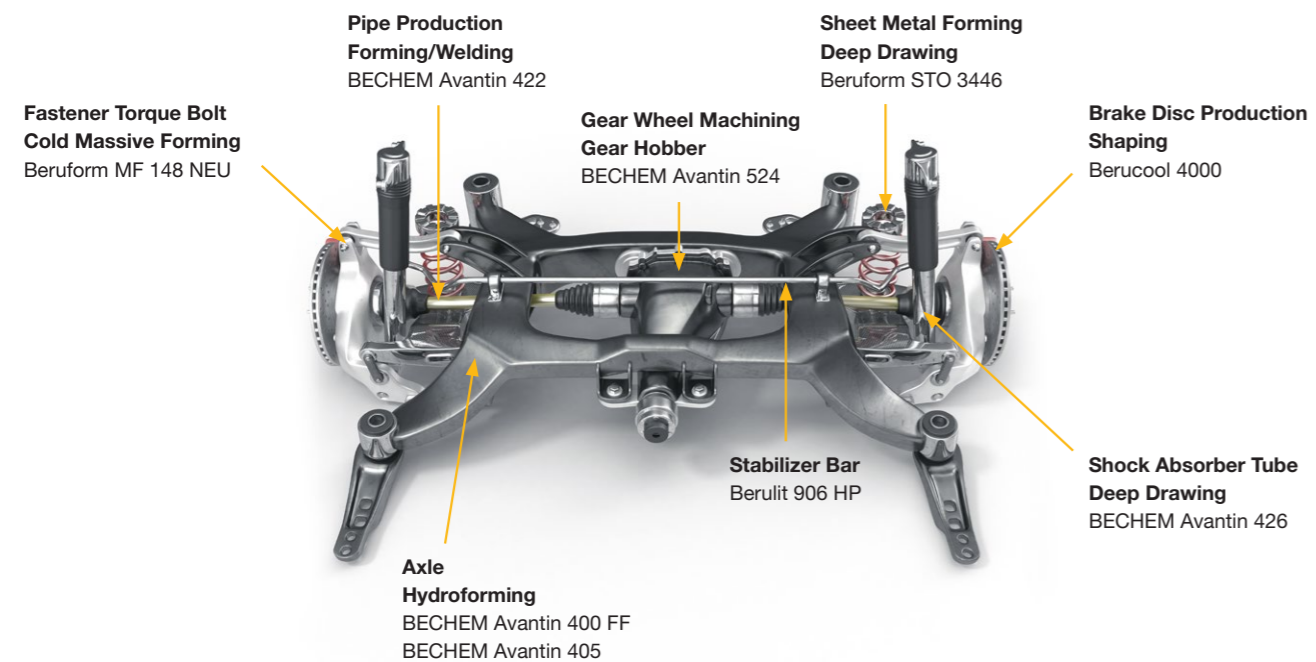

## WIRING SYSTEM



# Water miscible coolants

BEICHEM Avantin is a product series of water-miscible coolant lubricants that have ensured process reliability millions of times for decades. From the allrounder for multi-metal applications and the expert on series processing in automotive production lines, to the specialist in broaching and deep drilling operations, BEICHEM offers optimal and economical product solutions.

High-quality and globally available raw materials combined with the exceptional BEICHEM development know-how form the basis for processing fluids that meet highest standards. The adjustment to the permanently changing process parameter guarantee the continuous development of our products.

BEICHEM Avantin stays cool even when things get hot. Processes that involve high thermal loads are ideally supported by oxidation resistant, semi and fully synthetic product concepts. With minimal consumption, BEICHEM Avantin impresses by excellent cooling, outstanding corrosion protection, and excellent removal of process materials.



Large bore piston manufacturing with BEICHEM Avantin

» Amine-containing, boron- and FAD free\*. «

PRODUCT	Materials to be processed	Mineral oil ca. [%]	Lubrication Performance	Process	Description	
Contains mineral oil 	<b>BEICHEM Avantin 422</b> 	Cast iron, steel	20	♦♦	Grinding, turning, drilling, milling	Semi-synthetic formulation with excellent washing performance, low odor, outstanding corrosion protection for workpieces and machines, high pH stability, and strong resistance to microbial contamination.
	<b>BEICHEM Avantin 441-10</b> 	Low- to high-alloyed steels	38	♦♦	Grinding and demanding metal cutting, machine construction and toolmaking, motor- and drive components	Semi-synthetic formulation with excellent flushing properties, optimized for soft water, good corrosion protection, high emulsionstability, excellent filterability, good skin tolerance
	<b>BEICHEM Avantin 451</b> 	Aluminum, cast iron, nonferrous metals, steel, titanium	45	♦♦♦	General to demanding metal cutting, machining of engine blocks, cylinder heads, gear-box housings, pistons	Universal high-performance formulation for excellent surface qualities
	<b>BEICHEM Avantin 455</b> 	Aluminum, non-ferrous metals, steel, titanium	30	♦♦♦♦	Difficult machining, machining of engine blocks, cylinder heads, transmission housings, pistons	Excellent surface finishes, especially on aluminum alloys used in the automotive and aerospace industries
	<b>BEICHEM Avantin 438</b> 	High alloyed steels, nickelbased alloys	28	♦♦♦♦	Deep drilling, broaching, cylinder tube processing, demanding forming	Semi-synthetic high-performance formulation for excellent surface qualities and maximum tool life
	<b>BEICHEM Avantin 524</b> 	Aluminum, cast aluminum, cast steel, fiber-reinforced composites, nickel-chromium superalloys, stainless steel, steel, titanium	20	♦♦♦♦	Difficult machining of automotive, drivetrain, and aerospace components, engine components made of titanium and nickel-chromium superalloys, toolmaking	Water-miscible metalworking fluid for the most demanding applications, high lubricity, low foaming, high emulsion stability and biostability, very stable pH, excellent corrosion protection, strong cleaning performance, low top-up concentration, and good skin compatibility as confirmed by dermatological and allergological testing
Mineral oil-free 	<b>BEICHEM Avantin 400 FF</b> 	Cast iron, steel	0	♦	Grinding, disc grinding, plain- and flat grinding, roll grinding	Fully synthetic formulation, excellent coolant life due to special additive technology, excellent corrosion protection, low tendency to stick, excellent foaming properties
	<b>Berucool 4000</b> 	Cast iron, steel	0	♦♦	Plain- and flat grinding, roll grinding	Fully synthetic formulation, excellent corrosion protection, excellent foam behavior, low adhesion tendency, good skin tolerance
	<b>BEICHEM Avantin 405</b> 	Cast iron, steel	0	♦♦	General metal cutting and grinding, thread milling	Fully synthetic high-performance formulation, excellent temporary corrosion protection, very low consumption
	<b>BEICHEM Avantin 4015</b> 	Aluminum, steel	0	♦♦	General to demanding metal cutting and grinding, thread milling	Fully synthetic formulation for universal, high-performance implementation, excellent flushing properties, excellent corrosion protection
	<b>BEICHEM Avantin 404 HM</b> 	Carbide metal, casting, non-ferrous metals, steel	0	♦	Grinding of hard metals in the tool manufacturing	Fully synthetic formulation with cobalt leaching inhibition, good corrosion protection, high dirt-bearing capacity, excellent surface qualities, neutral odor
	<b>BEICHEM Avantin 4409</b> 	ADI-materials, high-tensile stainless steels, nickel-based alloys	0	♦♦♦♦♦	Deep drilling, broaching, cylinder tube processing, demanding forming	Fully synthetic high-performance formulation, highest tool life, excellent surface qualities, can also be used as additive and for forming processes
	<b>Beruffluid AS 1006</b> 	Aluminum, cast iron, steel	0	♦♦♦	General metal cutting and grinding	Synthetic, high-performance formulation, excellent flushing properties, excellent temporary corrosion protection, low adhesion tendency, good biostability, excellent foaming behavior
	<b>Beruffluid AS 1008</b> 	Aluminum, steel, titanium	0	♦♦♦♦	Drilling, turning, milling, optical components, control and regulation technology	High performance, extended tool life, excellent cooling properties, very good filterability, reduced aerosol formation, for individually and centrally supplied systems

\* Vrij van formaldehyde-depotstoffen, FAD      ♦ = low ... ♦♦♦♦♦ = very high

# For the highest of performances in metalworking: BECHEM XC Fluids

The new BECHEM XC Fluids establish a pioneering standard for metalworking fluids that are not miscible with water. Using innovative base fluids and synergistically active additive technologies results in new excellent performance benchmarks and optimized production processes.

BECHEM XC Fluids have been developed for demanding metal cutting and make a compelling case given their higher flash-points, low evaporation and reduced oxidation tendency, and they lead to increased performance and extended tool life.

The mineral oil-free BECHEM XC Fluids are based on synthetic base fluids and ensure a stable and safe production process. Users profit from improved work safety and low consumption. The continuously rising demands in metal cutting and machining processes require fluids with ever stronger performance. Berucut XC is the new generation of BECHEM metalworking fluids that have been developed today for the future already and which set the highest BECHEM standard.

## Cutting- and grinding oil performance

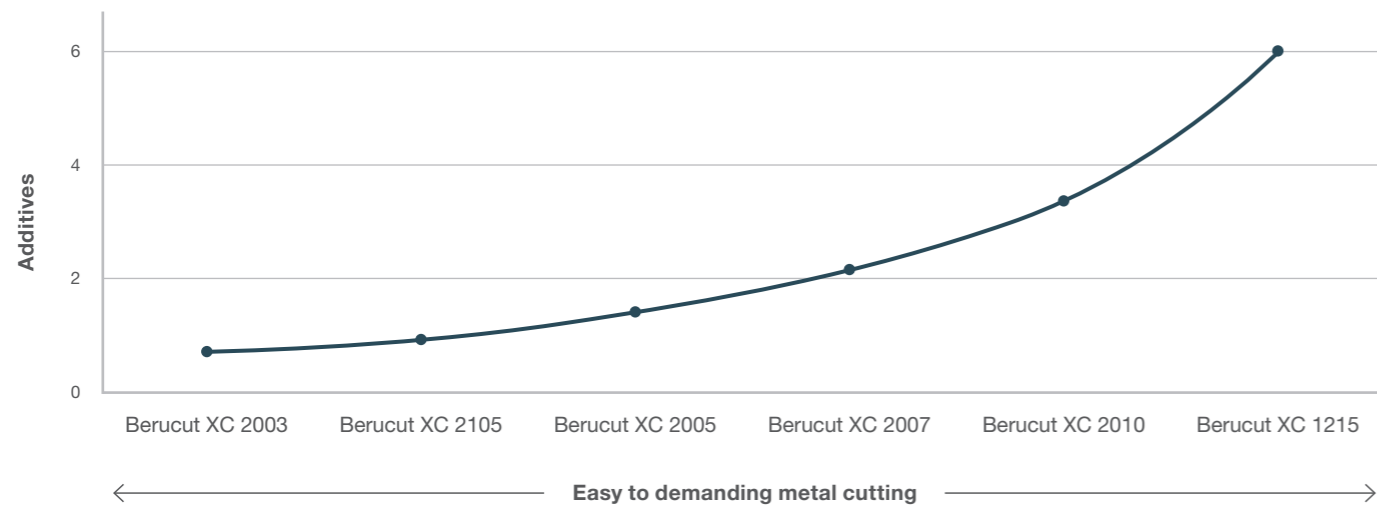

# Berucut XC – the new technology for more reliability and safety

## Evaporation loss [%]

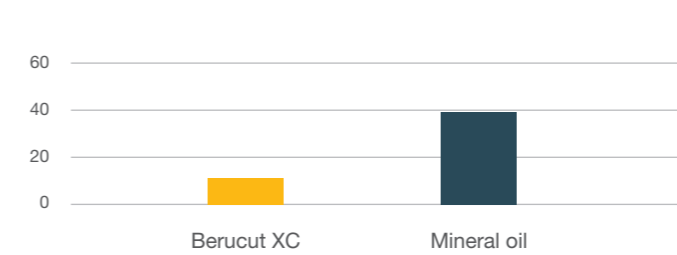

The evaporation loss of a base oil in increased temperatures is closely tied to the aerosol load of the direct machine environment. The poorer the evaporation characteristics of a metalworking medium, the more must be invested in suitable extraction systems. Compared to conventional mineral oils, the evaporation loss could be lowered by more than one-quarter through the use of Berucut XC and the odor build-up could be reduced significantly as well.

## Air separation characteristics [sec.]

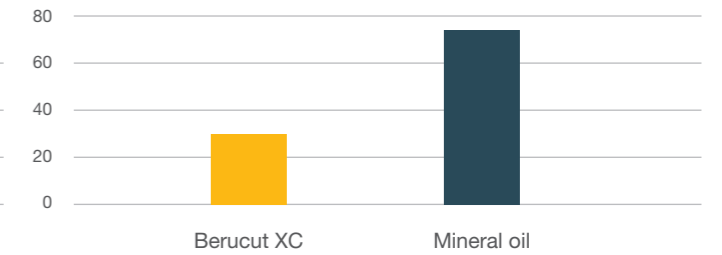

Modern metalworking processes use high lubricant oil pressures of 70 bar up to more than 100 bar. The air separation characteristics of the base oil therefore becomes an important factor in terms of quality, as the high shear strain when pumping the lubricant oil introduces a lot of air to the medium. Compared to conventional mineral oils, the air separation characteristics of the new Berucut XC series is up to three times faster.

## Viscosity at 10 °C [mm<sup>2</sup>/s]

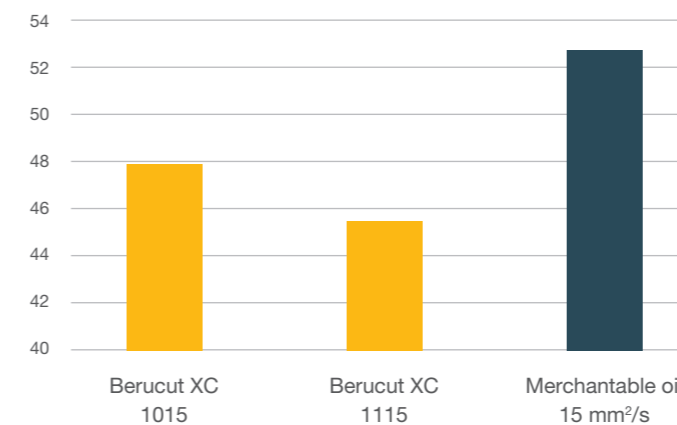

The lubrication performance of a metalworking medium is closely tied to the viscosity-temperature behavior. In deep temperatures, too strong a rise of the viscosity is counter-productive, as the cooling and flushing capacity of the oil reduces. This is decisive whenever a process has not reached its operating temperature yet. In very high temperatures, in contrast, the thickness of the available lubricant

## Viscosity at 200 °C [mm<sup>2</sup>/s]

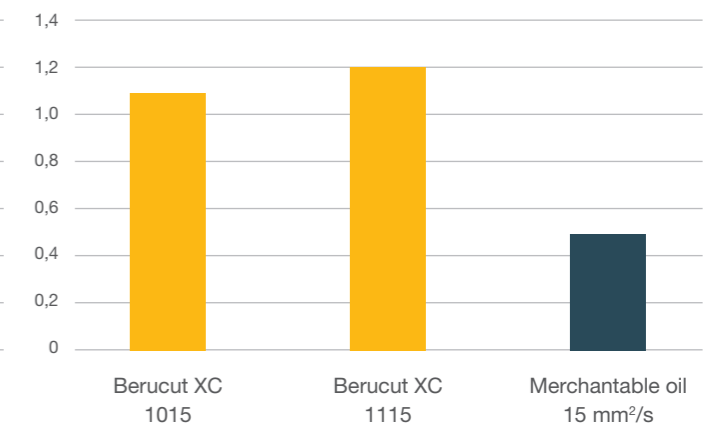

film is decisive because the aspect of cooling becomes less important. Compared to conventional metalworking oils, the Berucut XC series proves to have substantially better viscosity-temperature characteristics in both high as well as low process temperatures, whereby it contributes to a significant improvement of productivity.

# Grinding and machining

## Advantages of the Berucut XC series

- Excellent oxidation stability
- Very high flashpoint
- Very high viscosity index
- Very low evaporation loss
- Excellent UV stability
- Low pour point, good deep temperature behavior
- Very good lubrication performance
- High cutting speeds
- Good material compatibility
- Very good foam control
- Very low PAH values (polycyclic aromatic hydrocarbons)

# In-vitro cytotoxicity

Products that are used in medical technology must fulfill particularly strict standards regarding their toxicity and compatibility with biological systems. For medical products with longer-term or permanent tissue contact, the biological safety test for biocompatibility according to ISO 10993 is mandatory. The Berucut XC series has passed the test for in-vitro cytotoxicity according to DIN EN ISO 10993-5:2009 with the best possible rating (0 reactivity).



In the processing of implants made of titanium, Berucut XC guarantees very good surface and processing quality

PRODUCT	Materials to be processed	Kinematic viscosity [mm <sup>2</sup> /s] at 40 °C	Flashpoint [°C]	Performance additives	Machining	Process	Description
<b>Berucut XC 1010</b> 	Steel, stainless steel	13	185	••	medium to difficult	Turning, drilling, milling, grinding, deep drilling, thread milling, tooth flank grinding	High-performance AW/EP additives ensure a high load-carrying capacity and reduce wear and tear on the tool, support high cutting speeds, excellent flushing capacity
<b>Berucut XC 1015</b> 	Steel, stainless steel	16	185	••	medium to difficult	Turning, drilling, milling, grinding, deep drilling, thread milling, tooth flank grinding	High-performance AW/EP additives ensure a high load-carrying capacity while reducing wear and tear on the tool, support high cutting speeds, excellent flushing capacity, <b>in-vitro cytotoxicity according to DIN EN ISO 10993-5:2009 with the best possible rating (0 reactivity)</b>
<b>Berucut XC 1022</b> 	Cast iron, steel	21,5	185	••	medium to difficult	Turning, drilling, milling, grinding, deep drilling, tooth flank grinding	High-performance AW/EP additives ensure a high load-carrying capacity while reducing wear and tear on the tool, support high cutting speeds with excellent flushing capacity, extremely temperature-stable
<b>Berucut XC 1110</b> 	Cast iron, steel	10	190	••	medium	Grinding, simple metal cutting	Excellent surface qualities, excellent dispersing properties with excellent residue behavior
<b>Berucut XC 1115</b> 	Non-ferrous metals, stainless steel, steel	15	195	•••	medium to difficult	Turning, drilling, milling, grinding, deep drilling, thread milling, tooth flank grinding	High-performance AW/EP additives guarantee high load-carrying performance and reduced tool wear, low evaporation tendency, excellent flushing capacity, <b>in-vitro cytotoxicity according to DIN EN ISO 10993-5:2009 with the best possible rating (0 reactivity)</b>
<b>Berucut XC 1122</b> 	Non-ferrous metals, stainless steel, steel, titanium	21	185	••	medium	Turning, drilling, milling, grinding, deep drilling, thread milling, tooth flank grinding	High-performance AW/EP additives ensure a high load-carrying capacity while reducing wear and tear on the tool, support maximum cutting speeds at high-speed cutting with excellent flushing capacity, very temperature-stable
<b>Berucut XC 1215</b> 	Steel, stainless steel, titanium, copper alloys, aluminum alloys	16	202	••	medium to difficult	Turning, drilling, milling, deep drilling, thread cutting, tooth flank grinding	High-performance AW/EP additive technology, specially developed for copper-beryllium alloys and non-ferrous metals, for the aerospace and medical industries, with a very high flash point and very low evaporation losses
<b>Berucut XC 2003</b> 	Steel, stainless steel, aluminum, non-ferrous metals	3,4	136	•	easy	Cold rolling of sheet metals, punching, bending, edging, grinding	Very good surface qualities, low evaporative emissions, good rolling results at low rolling pressures
<b>Berucut XC 2105</b> 	Cast iron materials, steel, nonferrous metals	7	168	•	easy	Honing, grinding, finishing	Ensures excellent surface qualities, very low evaporation tendency, good cooling and flushing capacity, good corrosion protection, high-performance AW/EP additives
<b>Berucut XC 2005</b> 	Cast iron materials, steel, stainless steel, titanium, carbide metal, non-ferrous metals	6	170	•	easy	Grinding, honing, engraving	Excellent surface qualities, excellent dispersing properties with excellent residue behavior, <b>in-vitro cytotoxicity according to DIN EN ISO 10993-5:2009 with the best possible rating (0 reactivity)</b>
<b>Berucut XC 2007</b> 	Cast iron materials, steel, stainless steel, titanium, carbide metal, non-ferrous metals	8	185	•	easy	Grinding, honing, engraving	Excellent surface qualities with very low evaporation tendency, excellent dispersing properties with excellent residue behavior, <b>in-vitro cytotoxicity according to DIN EN ISO 10993-5:2009 with the best possible rating (0 reactivity)</b>
<b>Berucut XC 2010</b> 	Carbide metal, non-ferrous metal, stainless steel, steel, titanium	10	190	•	easy to medium	High speed, carbide metal processing, tooth flank grinding, tool manufacturing	Developed for high speed applications, for the aviation industry and medical technology, very good flushing effects, very low evaporation tendency, very good air separation characteristics

• = low ... ••••• = very high

# Deep drilling and broaching

BECHEM process oils of the Berucut series guarantee the best machining results even under the most severe conditions. Grinding processes exposed to high thermal stress, deep drilling operations in special materials, broaching processes with maximum feed rates, as well as optimised minimum quantity lubrication meet all challenges in serial production and always fulfill the highest expectations. The special BECHEM formulations set the standard in this industry.

BECHEM is a pioneer for innovations in national and international research projects. Our specialist inresearch, development and application technology create benefits and take responsibilities for processes that are exposed to permanent changes. BECHEM convinces as a strong partner with extraordinary expertise and product innovations.

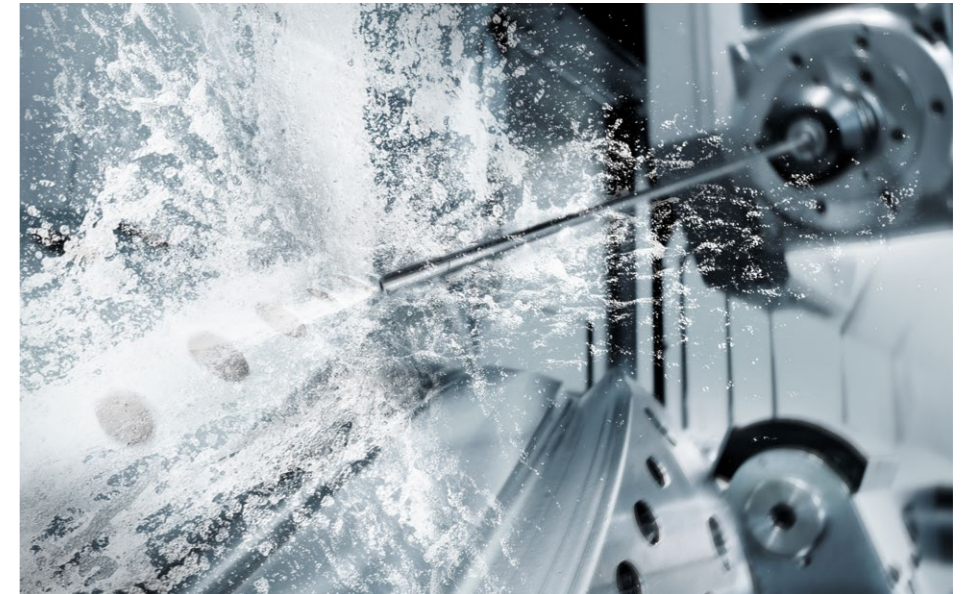

» Optimized processing oil makes efficient production processes possible. «

	PRODUCT	Materials to be processed	Kinematic viscosity [mm²/s] at 40 °C		Flashpoint [°C]	Performance additives	Machining	Process / Examples of application	Description
Broaching oils	<b>Berucut RMO TC 18 Package</b> 🔧 ⚙️	Stainless steel, steel	20	200	••••	medium to difficult	Vertical broaching (ball tracks)	Low-viscous additive package as a booster and as an additive for metalworking oils, in combination with broaching oils as an alternative to products containing chlorine	
	<b>Berucut RMO 822-8</b> 🔧 ⚙️ 🛠️	Stainless steel, steel	30	180	••••	difficult	Vertical broaching, sawing, thread milling, cold massive forming	High-performance AW/EP-additives for high load-carrying capacity and high cutting performance, good flushing capacity, an alternative to products containing chlorine	
	<b>Berucut RMO 35 ZF</b> 🔧 ⚙️ 🛠️	Stainless steel, steel	37	170	•••••	difficult	Twist broaching (gears), internal broaching, external broaching, sawing, thread milling	High-performance AW/EP-additives for high load-carrying capacity and high cutting performance, good flushing capacity, low evaporation tendency	
	<b>Berucut XC 5022</b> 🔧 ⚙️ 🛠️	Stainless steel, steel	22	190	••••	difficult	Vertical broaching, sawing, thread milling, cold massive forming	High-performance AW/EP additives for a high load-carrying capacity and strong cutting performance, excellent flushing capacity	
Deep drilling oils	<b>Berucut TBO 315</b> 🔧 ⚙️ 🛠️ 🔍	Stainless steel, steel	16	160	••	medium	Deep drilling (all methods), peeling, rolling, burnishing	Highest cutting performance and powerful additive package for excellent surfaces, avoids formation of built-up edges, excellent cooling properties, supports demanding machining processes where cross-bores are no problem, for steels with a tensile strength of up to 800 N/mm²	
	<b>Berucut TBO 422</b> 🔧 ⚙️ 🛠️ 🔍	Aluminum, nickelbase material, stainless steel, steel	23	185	••	medium	Deep drilling, peeling, rolling, burnishing, broaching, thread milling	High-performance additive package for excellent surfaces, highest cutting performance, suitable for steel, aluminum and nickel alloys with a tensile strength of up to 800 N/mm²	
	<b>Berucut XC 4015</b> 🔧 ⚙️ 🛠️ 🔍	Steel	15	187	•••	difficult	Deep drilling (all methods), peeling, rolling, burnishing	High-performance additive package for excellent surfaces, high performance in the cut, prevents build-up edges, strong cooling effect, supports demanding processing parameters, presence of cross-bores is not a problem	
	<b>Berucut XC 4122</b> 🔧 ⚙️ 🛠️ 🔍	Aluminum, copper based materials, nickel based material, stainless steel, steel	23	185	••	medium to difficult	Deep drilling, peeling, rolling, burnishing, broaching, thread milling	High-performance additive package for excellent surfaces, high performance in the cut, suitable for steels, aluminum and nickel base alloys with tensile strengths of up to 800 N/mm²	

• = low ... ••••• = very high

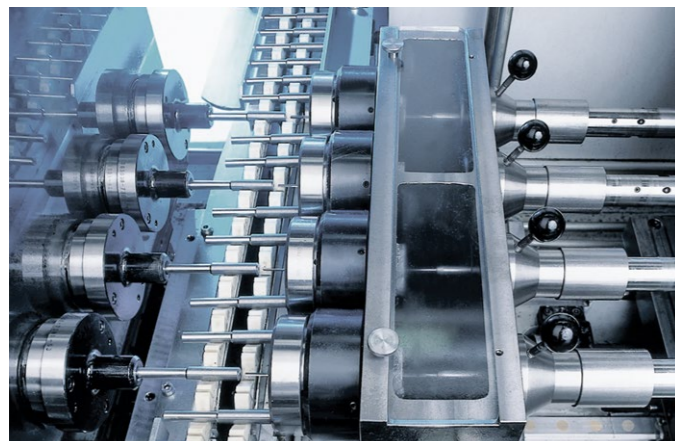

©TBT Tiefbohrtechnik GmbH+Co

# Clean and protect

## Cleaners

BECHEM offers the Beruclean series both in aqueous and solvent-based products for the residue-free cleaning of any process fluids in metalworking covering a wide range of materials and cleaning processes.

The **Beruclean neutral cleaners** are highly concentrated and therefore very economical in use. Due to the various application possibilities of Beruclean neutral cleaner, the number of products required for the process chain can also be reduced.

**Beruclean hydrocarbon cleaners** are particularly well-suited for cleaning organic contaminants, such as oil or grease, due to their high solvent power. BECHEM cold cleaners are virtually free of aromatic compounds and are characterized by a narrow boiling range, low consumption and short drying times.

## Influencing factors when choosing the right cleaner

An optimal cleaner affects the factors of time, temperature and costs.



## Corrosion protection

Extreme corrosion influences act on the manufactured components, such as semi-finished products or vehicle components, during long international transport routes and storage times. BECHEM has developed the **Beruprotect** product program especially for these requirements. Solvent-, oil-, and water-based products are mutually harmonised through modern additives for various applications in temporary corrosion protection.

**Dewatering fluids** are used for drying metal parts after treatment in an aqueous medium. The oily, waxy or vaseline-type film that forms protects against corrosive atmospheric influences and, to a limited extent, also against mechanical stresses.

**Corrosion protection oils** are used to apply oily protective films of different strengths and to preserve dry or oil-wet parts in intermediate storage for protection against moisture and corrosive components contained in ambient air. Humidity and other traces of water are partly absorbed by the protective film before they can penetrate to the base material and cause corrosion. BECHEM corrosion protection oils are also suitable for untreated ferrous metals as well as for galvanized or phosphated material.

## Cleaners

PRODUCT	Kinematic viscosity [mm <sup>2</sup> /s] at 40 °C	Flashpoint [°C]	Examples of application	Description
<b>Beruclean S 4033</b> 	1,6	≥ 62	Degreasing of metal parts and semi-finished products, for cleaning equipment, tools, engines, tank systems, chains, vehicles, removal of processing oils that are not mixed with water, corrosion protection media and waxes	Mixture of aromatic free hydrocarbons, narrow vacuum cut, dries quickly, virtually odorless
<b>Beruclean ECO</b> 	1,8	≥ 70	Removes oil, grease, wax, resin, bitumen, tar, oil carbon, non-hardened paints and varnishes	Multi purpose cold cleaner, free of aromatic hydrocarbons, nearly odor-free, strong dissolution effect, good cleaning effect, H1-registered

Carbon hydrate cleaning agent for manual cleaning

PRODUCT	pH value 5 %	Examples of application	Process	Description
<b>BECHEM Cleaner 3860</b> 	9,0	Aluminum, gray cast iron, steel, non-ferrous metals	Dip and ultrasonic degreasing (from 25 °C, depending on the level of contamination), as well as passivation (+20 °C to +70 °C for all processes)	Aqueous neutral cleaner, low-foaming, excellent soil-carrying capacity, very good material compatibility, good corrosion protection, optimal cleaning results, demulsifying
<b>BECHEM Cleaner 5134</b> 	9,0	Aluminum, gray cast iron, steel, non-ferrous metals	Spray cleaning as well as passivation (+45 °C to +70 °C for all processes)	Aqueous neutral cleaner, low-foaming, excellent soil-carrying capacity, very good material compatibility, good corrosion protection, optimal cleaning results, demulsifying
<b>Beruclean 111 EHF</b> 	13	Steel- and ferrous materials	Immersion, spray and ultrasonic cleaning (+50 °C to +80 °C for all processes)	Universal implementation, highly alkaline aqueous cleaner for steel and ferrous materials
<b>Beruclean 3849</b> 	1,5	Stainless steel, glass, ceramics	Immersion degreasing (+30 °C to +80 °C), manual cleaning, diluted in high-pressure cleaners	Liquid, phosphorous cleaning concentrate, removes organic and inorganic deposits, cleaning of acid-resistant materials, has anti-bacterial effect because of the very low pH-value

Concentrates for aqueous cleaning

## Corrosion protection

PRODUCT	Kinematic viscosity [mm <sup>2</sup> /s] at 40 °C	Flashpoint [°C]	Type of protective film	Period of protection internal storage	Period of protection external storage	Description
<b>Beruprotect DW 12 V</b> 	-	≥ 62	like vaseline, 1 µm	9–12 months	3–6 months	Universal product, compensates acidic ingress after galvanic processes, forms a thin, vaseline-like and stable film, excellent dewatering properties, free of aromatic hydrocarbons and heavy metals
<b>Beruprotect 30 W – 35 W</b> 	-	≥ 62 ≥ 100	waxy, 4 µm	12–15 months	6–8 months	Very strong waxy corrosion protection film for highest requirements imposed on temporary prevention, suitable for overseas transports, good dewatering properties, free of aromatic hydrocarbons and heavy metals
<b>Beruprotect M 20 – M 80</b> 	20 40 50 80	≥ 155 ≥ 170 ≥ 170 ≥ 150	oily	4–5 mon. 6–8 mon. 8–10 mon. 10–12 mon.	2–3 mon. 3–4 mon. 5–6 mon.	From very fluid penetrating oil for corrosion protection to oil for the preservation of hardware- and bulk material and oil for polishing and corrosion protection with low forming properties, suitable for preserving belt material and to align steel bars and pipes

Dewatering Fluids

Corrosion protection oils

PRODUCT	Temperature range [°C]	Period of protection internal storage	Period of protection external storage	Description
<b>BECHEM High-Lub SW 2 Spray</b> 	-25 – 80	up to 2 years	up to 1 year	Corrosion protection grease with particularly good water resistance and excellent corrosion protection, including against seawater, very high wear protection thanks to EP additives

Spray

# Machine lubrication

For multiple applications in machine lubrication, BECHEM offers a product range that contributes significantly to the most modern production- and manufacturing technology as well as service and maintenance. BECHEM hydraulic fluids reduce friction and wear, including at high thermal loads, and inhibit corrosion with special additives, even under extreme loads. High performance gear oils and circulating oils from BECHEM also meet the requirements for

wear protection even under high mechanical and dynamic loads and convince with very good air and water release properties. In slideway oils, friction and wear reducing additives ensure smooth machine table sliding in guide rails, even at slow sliding speeds and high specific surface pressures.

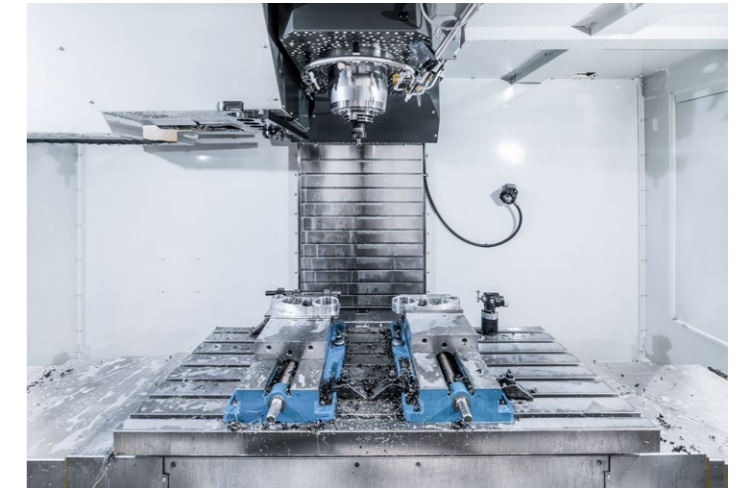

» Lubrication solutions for all machine components. «

	PRODUCT	Base oil	Kinematic viscosity [mm <sup>2</sup> /s] at 40 °C		Viscosity index	Pourpoint [°C]	Flashpoint [°C]	Specification	Type	Description
			10 to 68	≥ 95						
Hydraulic oil	<b>BECHEM Staroil NR 10 → 68</b> ↓ ↓ ↓	Mineral oil	10 to 68	≥ 95	-30 to -24	≥ 150 to ≥ 230	DIN 51524-2	HLP	Hydraulic oil with high thermal stability and resistance to oxidation, excellent protection against wear and corrosion, excellent air and water separation capacity as well as outstanding viscosity/temperature behavior, free of zinc	
Gear oil	<b>BECHEM Staroil G 100 → 680</b> ⊙ ⊙	Mineral oil	100 to 680	95 to 100	-33 to -18	≥ 230 to ≥ 270	DIN 51517-3	CLP	High-performance gear oil for spur, bevel, planetary and worm gears, excellent wear protection, very high ageing resistance, good load-carrying capacity and viscosity/temperature behavior, excellent water and air separation capacity	
Spindle oil	<b>BECHEM Spindle Oil 2</b> ⊙ ⊙ ⊙ ⊙	Mineral oil	2,3	-	-	≥ 101	-	-	Non-water miscible spindle oil for the lubrication of fast running machine spindles, good cooling and lubricity, acid-free, non-resinous, effective water separation, good corrosion protection, chlorine-free	
Slideway oils	<b>BECHEM Staroil CGLP 32 → 220 MF</b> ⊙ ⊙ ⊙ ⊙	Mineral oil	32 to 220	95 to 110	-35 to -20	≥ 170 to ≥ 200	DIN 51502	CGLP, CLP	Multifunctional CGLP slideway oils and CLP gear oils, optimal adhesion on slide- and guide rails, very good aging resistance, very good load carrying capacity, excellent water separation capacity, very good non-ferrous metal tolerance, good AW/EP properties, chlorine- and heavy metal-free	
Slideway grease	<b>Berutox M 21 EPK 420</b> ⊙ ⊙ ⊙ ⊙	Minerale olie	490	-	-	-	-	-	Semi-fluid grease for heavily loaded rolling bearings, gearboxes, and worm gears, with outstanding corrosion protection, particularly strong adhesion, excellent water resistance, and good flowability	

	PRODUCT	Base oil	Thickener	NLGI-grade	Kinematic viscosity [mm <sup>2</sup> /s] at 40 °C		Service temperature range [°C]	Process/ Examples of application	Description
					100 to 10	-40			
Spindle grease	<b>Berutemp PE 2-10 HS</b> ⊙ ⊙ ⊙ ⊙	Synthetic ester	Polyurea	2	100 to 10	-40	140	Ball bearings in the drivetrain of electric vehicles, high-speed rolling bearings, high-speed spindle bearings, for example in machine tools and textile machinery, low-noise rolling bearings in household appliances, gears in small gearboxes, worm gears	Excellent performance in the WS 22 high-speed bearing test rig (speed factor n × dm in hybrid bearings: 2.25 million), low-noise, suitable for very high and very low temperatures, high load-carrying capacity
	<b>Berutox FB 22</b> ⊙ ⊙ ⊙ ⊙	Polyalpha-olefin (PAO)	Barium complex soap	2	50 to 8	-40	180 to 200	High speed spindle bearings e.g. in tools and textile machines, high speed ball- and slide bearings, threaded spindles, gearwheels in compact gearboxes, worm gears, electric motor and fan bearings, bearings for guide rollers and slitting machines	For long-term lubrication at high speeds, good consistency-temperature-behavior, excellent water resistance, excellent corrosion and wear protection, good pumpability

<sup>1)</sup> Value in grey indicates a possible short-term maximum temperature



# Beruclean 3050 – Machine and floor cleaning agent

BECEM also offers a product range of high-performance machine and floor cleaning agents, besides the complete range of fully matched process fluids, industrial cleaning agents and corrosion protection agents for the metal-processing industry.

Beruclean 3050, the mildly alkaline, intensive special cleaner, permits effortless removal of industrial contamination and effective cleaning and care of industrial floors, motors, vehicles and machinery. It can be used on concrete, sealed- and coated floors or on even floor surfaces such as slabs, tiles and plastic. High solubility makes Beruclean 3050 particularly suitable for cleaning organic deposits such as oils, greases, waxes and tars while protecting surfaces. Beruclean 3050 will not attack surfaces of aluminum, cast iron or steel and is neutral on varnishes, rubber seals, plastics and textiles.

Beruclean 3050 was developed especially for scrubbing machines, high pressure- and steam jet devices and manual cleaning procedures. The contents conserve resources and a low-consumption formulation ensures maximum cost effectiveness and excellent cleaning results.

» For all surfaces  
and all  
applications.«



Beruclean 3050 is very good for the residue-free cleaning and care of sealed and coated floors

# BECEM scientific network

Thanks to intensive R & D work, as well as the participation in various international and national research projects, BECEM has successfully tailored their high-performance lubricants to the corresponding application. Modern test equipment and control benches allow the optimal selection of the suitable lubricant already during the early stage of development. BECEM finds the right solution which contributes to our customers' success.

» Innovation drives  
sustainability.«

## Awarded

High-quality lubricants are indispensable products that are worth their investment. They have received prestigious awards – by making a decisive contribution to performance, energy efficiency and sustainability of products and processes.

BECEM wins the award for innovative lifetime lubrication of various vehicle components.



BECEM as an award-winner is one of the 20 most innovative companies in North Rhine-Westphalia.



BECEM wins award for tailored solutions in the premium vehicle sector.



Award for Berufluid – a joint project with Fraunhofer Institute IVV and IWF Braunschweig.



BECEM wins the NRW Efficiency Award for innovative and resource-efficient coating in cold massive forming.

# BECHEM – the brand for high performance lubricants

BECHEM stands for outstanding high performance lubricants developed in collaboration with leading machinery manufacturers and technical colleges. We move solutions along and develop tomorrow's products sustainably and compatible with standards. They safeguard people, machinery and resources and additionally go far beyond the REACH requirements, the VSI specifications, and the VDI 3035 and VDI 3397 guidelines. Many products for the metal processing industry have skin assessments and a number of medical approvals.

As one of the leading companies in lubricant technology, we contribute significantly to the success of our customers. We consider ourselves a development partner in industry and problem solvers in questions related to lubrication technology in the most varied markets. Our high level of competence in tailored, innovative ideas leads our tribology specialists to develop pioneering innovations such as, for example, Berufluid cooling lubricant, which has been distinguished with the Deutscher Rohstoff Effizienz Preis (German Raw Material Efficiency Prize).

Our water-based, mineral oil-free Berufluid cooling lubricants have led to a completely new cooling lubricant category in addition to the conventional water miscible and non-water miscible metal processing media, making more sustainable and energy efficient manufacturing possible and providing answers to raw material questions of the future, even today.



» Everything from one source. «

# Development expertise and service

At the BECHEM technical center, the latest chemical-physical testing and analysis systems are available that are used to characterize lubricants, to monitor their application, to analyze customer problems and finally to develop the appropriate lubricant solutions. Cutting-edge opportunities for testing can simulate the most varied conditions under which lubricants are used around the world.

In many applications and components, lubricants and lubrication systems are a critical feature in development, and cannot be considered separate from the respective project. Product success hinges on lubricants tailored to the requirements profile. Powerful analysis is crucial here.

The performance capacity of the products used, and competent technical service, are crucial inputs to guarantee each industrial challenge is met with sufficient proficiency to create success stories. BECHEM has the necessary expertise to provide individual consultation to users and to assess the effectiveness of system solutions.

The BECHEM service department ensures continuous improvement of processes:

- Inventory/analysis on site
- Analysis at the BECHEM technical center
- Development of tailored system solutions
- Extensive tests in the work process
- Process-oriented technical support
- Optimized service life
- Improved working conditions for users
- Full fluid management



# Metalworking Machining



We're there when the job  
gets really demanding

---

LUBRICATION SOLUTIONS FOR INDUSTRY

CARL BECHEM GMBH · Weststr. 120 · 58089 Hagen · Germany · Phone +49 2331 935-0 · bechem@bechem.de · www.bechem.com